

SURFACE KEY

MAGENTA	visible (general) surface
RED	70-120µm (main surface)
GREEN	40-120µm (secondary surface)
CYAN	0-120µm (tertiary surface)
BLUE	0-30µm only powdermist
ORANGE	free of coating
VIOLETT	high gloss
WITHOUT COLOUR	raw
BROWN	according info

FUNCTION OF THREADS MUST BE GIVEN AFTER COATING

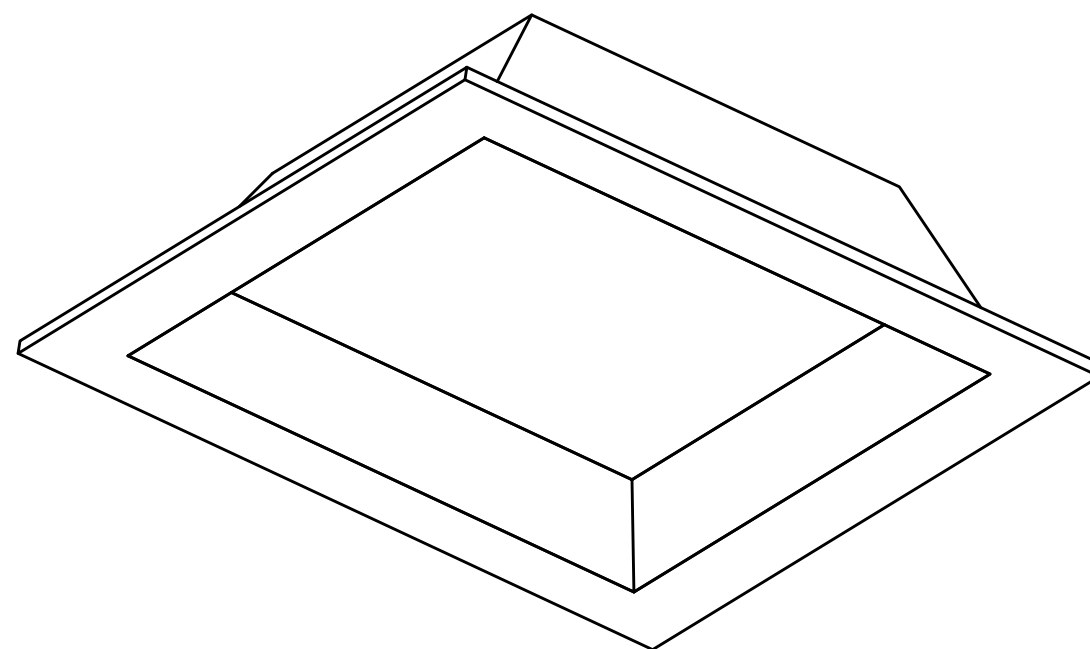
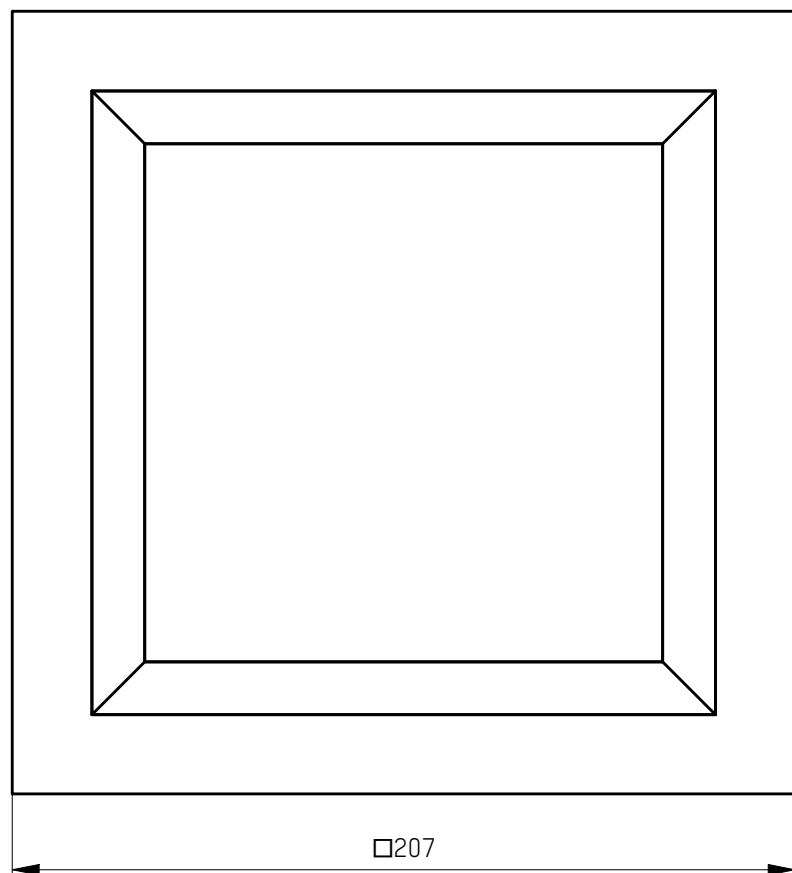

rev.	description	checked date	checked by
01	material undefined	29.01.2025	Fink
00	first release	29.10.2024	Fink

REVISIONS-HISTORY

technical information / manufacturing note		general manufacturing tolerances N/A	drawn by fink	MOLTO LUCE®
		material ACC. TECHN. INFO	creation date 23.10.2024	
weight 0,000 kg	surface 150772 mm ²	description SIMPLE	drawing number ENG000036810	
surface finish N/A	surface according ISO 1302	undimensioned edges according DIN ISO 13715	revision 01	
		article number 227-01231xxxxxxxxxx	scale 1:2	
all dimensions and tolerances related uncoated surfaces		max. thickness of coating: 120µm	sheet 1 of 1 A3	

The unauthorized and / or against the rules use of these documents and possible attachment are not permitted and are judicially pursued